

# SST-36-N/NE

Non-Insulated Articulated/Telescopic Aerial Lift

**WORKING HEIGHT:** 40 ft 6 in (12.3 m)

**HORIZONTAL REACH:** Up to 26 ft 7 in (8.1 m)

**PLATFORM CAPACITY:** Up to 400 lbs (181 kg)

**DEMAND  
BETTER.  
DEMAND  
VERSALIFT.**



*SST-36-NE shown with positioner.*



**VERSALIFT** is a leading global manufacturer of bucket trucks, digger derricks, cable placers and other specialty equipment for use in the power generation, transmission and distribution, investor-owned utility, telecommunications, bridge inspection, light and sign, and forestry industries. Providing equipment sales, service, training, warranty and financing to government agencies, corporations, contractors, co-ops and municipalities through its global network of facilities and distributors, the company employs more than 900 employees worldwide.

# SST-36-N/NE



Non-Insulated Articulated/Telescopic Aerial Lift

## GENERAL SPECIFICATIONS:

### Horizontal Reach

SST-36-N 24 ft 8 in (7.5 m)

SST-36-NE 26 ft 7 in (8.1 m)

Standard Platform Capacity 350 lbs (160 kg)

Max Platform Capacity (-NE only) 400 lbs (181 kg)

Outer Boom Lift Eye Capacity 500 lbs (227 kg)

## WITH STANDARD PEDESTAL:

Height to Bottom of Platform 35 ft 6 in (10.8 m)

Working Height 40 ft 6 in (12.3 m)

Stowed Travel Height 10 ft 5 in (3.2 m)

## BOOM ACTION:

Inner Boom Extension 116 in (2.9 m)

Inner/Outer Boom Articulation  $-14^{\circ}$  to  $+74^{\circ}$

Lower Boom Articulation  $-6^{\circ}$  to Vertical

## HYDRAULIC SYSTEM:

Operating Pressure 2250 psi (155 bar)

Flow Rate 2 gpm (7.57 lpm)

Filtration 10 micron return

System Type Open Center

## OPTIONS:

- Hydraulic Platform Leveling (Standard on -NE)
- Backup 12-Volt Pump
- Rear Torsion Bar
- Independent H Frame Outriggers
- Hand-Held Remote Lower Control
- 120 Volt Receptacle at Platform
- Two Speed Bottom Controls
- Various Platforms, Doors and Covers
- Various Pedestal Heights
- Pneumatic Circuit to the Platform

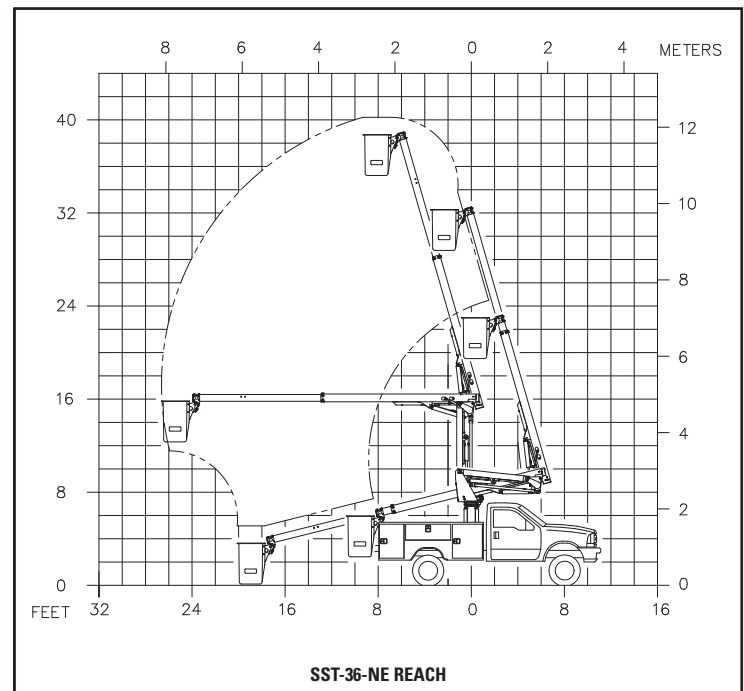
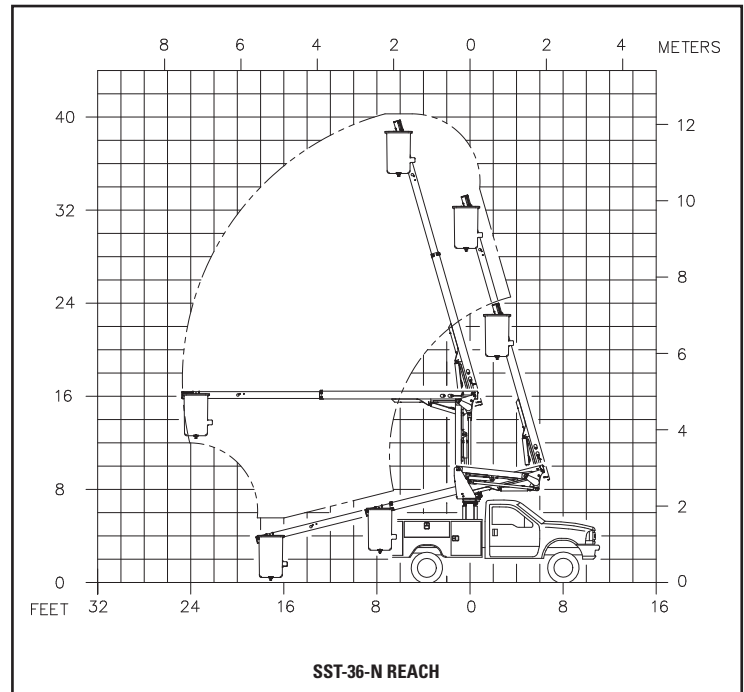

Note: Specifications on units may vary or change without prior notifications due to option selections.