



KEY FEATURES

- 65' working height, 59' working side reach on 25,999 lb. non-CDL chassis
- Over 3,300 lbs. of toolbox capacity
- 600 lb. platform capacity
- 160-degree platform rotation
- User choice of single-stick or three-stick remote controls
- Short-jack capability with one side vertical outrigger deployment for work in confined spaces
- Stow & Go platform jib with unrestricted 500 lb. capacity



Stow & Go Platform Jib

Stows in platform and requires no assembly. 500 lb. capacity in all positions and 2 feet beyond platform rail eliminates guesswork.



Office in the Sky Accessories

110V, welder, oxy/acetylene, hydraulic tools, pressure washer and other outlets located conveniently in work platform.



160 Degree Platform Rotation

Maximizes the work you can do in a single set up



Over 3,300 lbs. Toolbox Capacity

On non-CDL chassis saves fuel and gives more space for tools



Heavy Duty Structural Components

Robust subframe, turret, bearing, outriggers and boom for smooth ride and exceptionally long useful life

OTHER FEATURES

- **Hydraulic System:** High-performance hydraulics provide smooth operation. Continuous rotation, Pressure and return filtration. 33% fewer hydraulic fittings reduce potential leak points.
- **Controls:** Your choice of three stick or single stick proportional remote controls with hi/low range and hi/low engine speed for smooth operation in tight spaces. Three stick lower remote controls provide consistent operation. Automatic function slowdown approaching limits during short jack operation. USB charger at upper controls.
- **Bluetooth Remote Diagnostics:** Improves serviceability and reduces downtime. Provides real-time operator feedback.
- **Low Profile Bed and Step Bumper:** With integrated tie down rails for ergonomic access
- **Lifetime Structural Warranty:** For your peace of mind
- **Certification:** Certified to ANSI A92.2 for Vehicle Mounted Elevating and Rotating Devices

**Specifications are subject to change.*

Build for You

MAIN BOOM LOAD RATINGS
WITH PLATFORM REMOVED*

*DEDUCT 500 LBS WITH PLATFORM ATTACHED

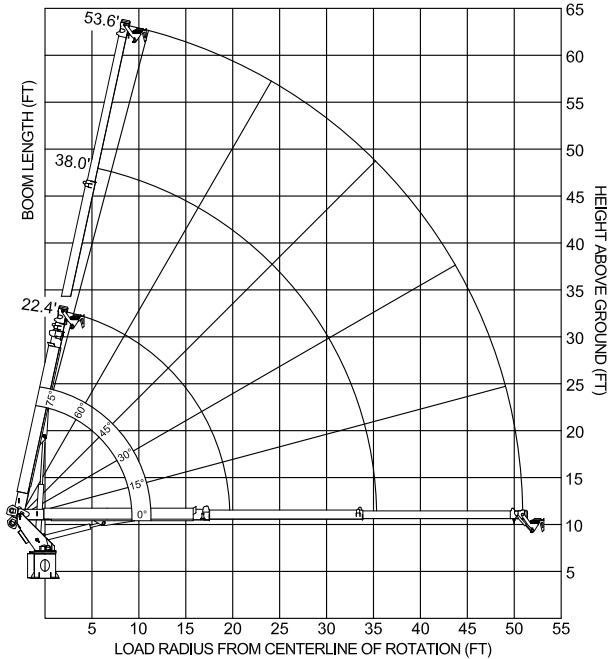

MAXIMUM WORKING LOADS
AERIAL PLATFORM OPERATION
USE OUTRIGGERS AT ALL TIMES - AVOID JERKING LOADS

MAX PLATFORM CAPACITY:
600 LBS
MAX JOB CAPACITY:
500 LBS

TOTAL COMBINED PLATFORM CAPACITY DIAGRAM (LBS)

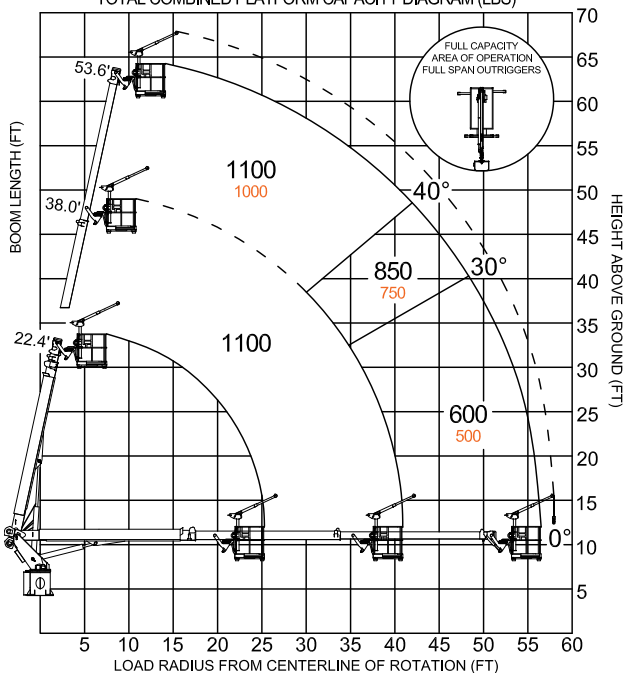

TECHNICAL SPECIFICATIONS

Working Height	65' / 19,8 m
Working Side Reach	59' / 17,9 m
Platform Capacity	600 lb / 272 kg
Main Winch Capacity	5,900 lb/2676 kg
Jib Winch Capacity	500 lb/227 kg
Front Outrigger Spread	12'/3,7 m
Rear Outrigger Spread	17'/5,2 m
Minimum GVWR	25,999 lb / 11793kg

AVAILABLE OPTIONS

- 500 lb. Capacity Stow & Go Jib Winch in Platform
- 5,900 or 2,000 lb Capacity Main Boom Winch
- Office in the Sky Accessories – 110V, welder, oxy/ acetylene, hydraulic tools, pressure washer and more
- Sign Forks on Work Platform
- Walkway Access to Platform
- Steel or Aluminum Toolboxes
- Steel, Wood or Aluminum Flatbed
- Composite or Wooden Outrigger Pads
- Platform Work Lighting
- Rear Back Up Camera
- Warning Lighting
- Overcab Protection
- Red, White or Custom Paint Colors
- 'Built for You' Additional Customization for Your Unique Application